

NEO-7P

u-blox 7 GPS/GNSS module with Precise Point Positioning

Data Sheet

Highlights

- Multi-GNSS engine for GPS, GLONASS, Galileo and QZSS
- Precise Point Positioning (GPS)
- Combines low power consumption and high sensitivity
- Simple integration with u-blox wireless modules
- Backward compatible with NEO-6 and NEO-5 families
- Raw measurement output



16.0 x 12.2 x 2.4 mm

www.u-blox.com

Document Information

Title	NEO-7P
Subtitle	u-blox 7 GPS/GNSS module with Precise Point Positioning
Document type	DATA SHEET
Document number	GPS.G7-HW-13044
Document status	Advance Information

Document status information

Objective Specification	This document contains target values. Revised and supplementary data will be published later.
Advance Information	This document contains data based on early testing. Revised and supplementary data will be published later.
Preliminary	This document contains data from product verification. Revised and supplementary data may be published later.
Released	This document contains the final product specification.

This document applies to the following products:

Name	Type number	ROM/FLASH version	PCN reference
NEO-7P	NEO-7P-0-000	FW 1.00	N/A

This document and the use of any information contained therein, is subject to the acceptance of the u-blox terms and conditions. They can be downloaded from www.u-blox.com.

u-blox makes no warranties based on the accuracy or completeness of the contents of this document and reserves the right to make changes to specifications and product descriptions at any time without notice. Reproduction, use or disclosure to third parties without express permission is strictly prohibited. Copyright © 2013, u-blox AG.

u-blox® is a registered trademark of u-blox Holding AG in the EU and other countries. ARM® is the registered trademark of ARM Limited in the EU and other countries.



Contents

Contents	3
1 Functional description.....	5
1.1 Overview	5
1.2 Product features	5
1.3 GNSS performance	6
1.3.1 GPS performance	6
1.3.2 GLONASS performance	7
1.4 Block diagram.....	8
1.5 GNSS.....	8
1.5.1 GPS.....	8
1.5.2 GLONASS.....	8
1.5.3 QZSS.....	8
1.6 Precise Point Positioning	9
1.7 Raw data	9
1.8 Differential-GPS.....	9
1.9 Augmented GPS.....	10
1.9.1 Assisted GPS (A-GPS).....	10
1.9.2 AssistNow Autonomous	10
1.9.3 Satellite-Based Augmentation System (SBAS).....	10
1.10 EXTINT: External interrupt	10
1.10.1 Pin Control.....	11
1.10.2 Aiding	11
1.11 TIMEPULSE.....	11
1.12 Protocols and interfaces.....	11
1.13 Interfaces.....	11
1.13.1 UART.....	11
1.13.2 USB.....	11
1.13.3 SPI.....	12
1.13.4 Display Data Channel (DDC).....	12
1.14 Clock generation	12
1.14.1 Oscillators.....	12
1.14.2 Real-Time Clock (RTC)	12
1.15 Power management.....	12
1.15.1 DC/DC converter	12
1.15.2 Operating modes	13
1.16 Antenna.....	13
2 Pin Definition.....	14
2.1 Pin assignment	14
3 Configuration management	15
3.1 Interface Selection (D_SEL).....	15

4	Electrical specification	16
4.1	Absolute maximum ratings	16
4.2	Operating conditions	17
4.3	Indicative current requirements	18
4.4	SPI timing diagrams	19
4.4.1	Timing recommendations	19
4.5	DDC timing diagrams	19
5	Mechanical specifications	20
6	Reliability tests and approvals	21
6.1	Reliability tests	21
6.2	Approvals	21
7	Product handling & soldering	22
7.1	Packaging	22
7.1.1	Reels	22
7.1.2	Tapes	22
7.2	Shipment, storage and handling	23
7.2.1	Moisture Sensitivity Levels	23
7.2.2	Reflow soldering	23
7.2.3	ESD handling precautions	23
8	Default messages	24
9	Labeling and ordering information	25
9.1	Product labeling	25
9.2	Explanation of codes	25
9.3	Ordering codes	25
	Related documents	26
	Revision history	26
	Contact	27

1 Functional description

1.1 Overview

NEO-7P is one of u-blox' NEO-7 series of standalone GPS/GNSS modules benefiting from the exceptional performance of the u-blox 7 multi-GNSS (GPS, GLONASS, Galileo, QZSS and SBAS) engine. NEO-7P brings Precise Point Positioning (PPP) technology using GPS signal carrier-phase to maintain the precision of every individual fix without restricting user dynamics. NEO-7P is ideal for portable, survey, agricultural, machine control, sports and leisure applications where clear-sky visibility enables continuous carrier-phase tracking.

The NEO-7 series provides maximum sensitivity while maintaining low system power. The NEO form factor allows easy migration from previous NEO generations. Sophisticated RF-architecture and interference suppression ensure maximum performance even in GPS-hostile environments.

The NEO-7 series combines a high level of integration capability with flexible connectivity options in a miniature package. This makes it perfectly suited for a wide range of applications with strict size and cost requirements. The I²C compatible DDC interface provides connectivity and enables synergies with u-blox SARA, LEON and LISA wireless modules.

u-blox 7 modules use GPS/GNSS chips qualified according to AEC-Q100 and are manufactured in ISO/TS 16949 certified sites. Qualification tests are performed as stipulated in the ISO16750 standard: "Road vehicles – Environmental conditions and testing for electrical and electronic equipment".

1.2 Product features

Model	Type	Supply	Interfaces	Features
	GPS QZSS GLONASS Timing Dead Reckoning Precise Point Positioning	2.7V – 3.6 V 1.65 V – 3.6 V Lowest power (DC/DC)	UART USB SPI DDC (I ² C compliant)	Programmable (Flash) Data logger Extra front-end LNA Front-end SAW filter Oscillator RTC crystal Antenna supply Antenna short circuit detection/protection Antenna open circuit detection pin Timepulse External interrupt/ Wakeup
NEO-7P	• • S •	• •	• • Sel •	• • C • o o o • •

Sel = Select for either SPI or UART/DDC by HW configuration pin (D_SEL)

o = Optional, requires external components

S = Standard Point Positioning only

C = Crystal

1.3 GNSS performance

1.3.1 GPS performance

Parameter	Specification	NEO-7P
Receiver type	56 Channels GPS L1C/A SBAS L1C/A QZSS L1C/A GALILEO E1B/C ¹	
Time-To-First-Fix ²	Cold Start	30 s
	Warm Start	28 s
	Hot Start	1 s
	Aided Starts ³	5s
	PPP	600s
Sensitivity ⁴	Tracking and Navigation	-161dBm
	Reacquisition	-160dBm
	Cold Start	-147dBm
	Warm Start	-148dBm
	Hot Start	-155dBm
	PPP	-147dBm
Horizontal position accuracy ⁵	Autonomous	2.5m
	SBAS	2.0m
	PPP ⁶	<1.0m
Accuracy of time pulse signal	RMS	30ns
	99%	60ns
Frequency of time pulse signal		0.25 Hz ... 10 MHz (configurable)
Max navigation update rate		10Hz
Velocity accuracy ⁷		0.1 m/s
Heading accuracy ⁶		0.5 degrees
Operational limits ⁸	Dynamics	≤ 2 g
	Altitude	50,000 m
	Speed	500 m/s

Table 1: GPS performance

¹ Ready to support GALILEO E1B/C when available

² All signals at -130dBm

³ Dependent on aiding data connection speed and latency

⁴ Demonstrated, with a good external LNA

⁵ CEP, 50%, 24 hours static, -130dBm, >6 SVs

⁶ Using WAAS

⁷ 50% @ 30m/s

⁸ Assuming Airborne <2 g platform

1.3.2 GLONASS performance

Parameter	Specification	NEO-7P
Receiver type	56 Channels GLONASS L1OF	
Time-To-First-Fix ⁹	Cold Start	32 s
	Warm Start	25 s
	Hot Start	1 s
Sensitivity ¹⁰	Tracking and Navigation	-158dBm
	Reacquisition	-156dBm
	Cold Start	-139dBm
	Warm Start	-145dBm
	Hot Start	-155dBm
	PPP	N/A
Horizontal position accuracy ¹¹		4.0m
Accuracy of time pulse signal	RMS	50ns
	99%	100ns
Frequency of time pulse signal		0.25 Hz ... 10 MHz (configurable)
Max navigation update rate		1Hz
Velocity accuracy ¹²		0.1 m/s
Heading accuracy ¹¹		0.5 degrees
Operational limits ¹³	Dynamics	≤ 2 g
	Altitude	50,000 m
	Speed	500 m/s

Table 2: GLONASS performance

⁹ All signals at -130dBm

¹⁰ Demonstrated, with a good external LNA

¹¹ CEP, 50%, 24 hours static, -130dBm, >6 SVs

¹² 50% @ 30m/s

¹³ Assuming Airborne <2 g platform

1.4 Block diagram

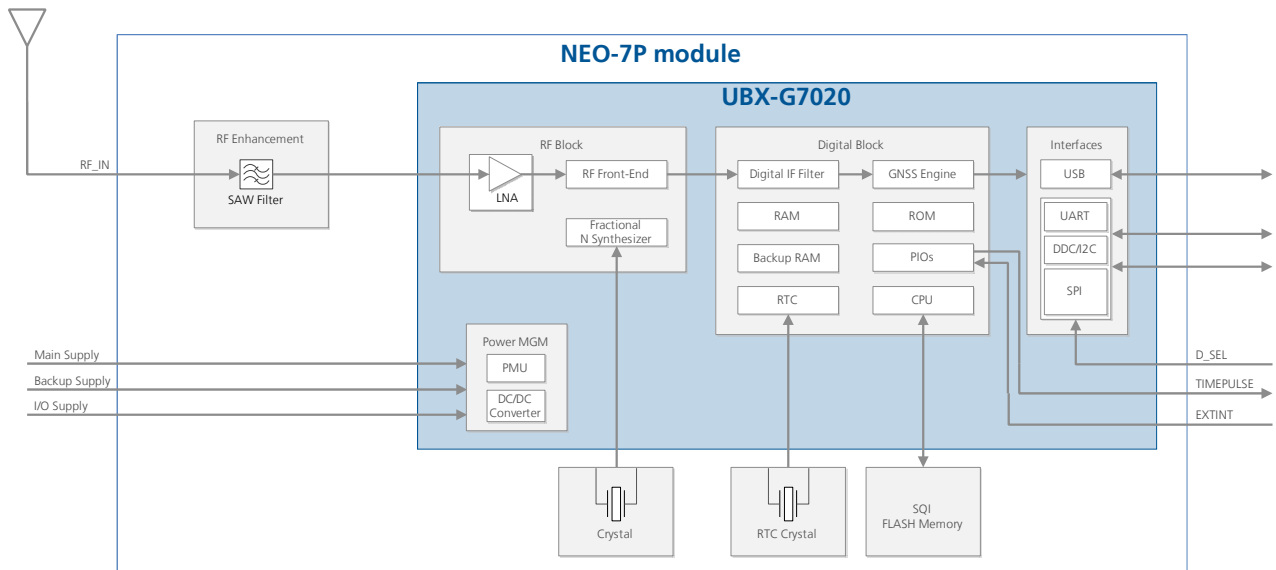

Figure 1: NEO-7P block diagram

1.5 GNSS

u-blox 7 positioning modules are multi-GNSS receivers and can receive and track GPS, GLONASS, GALILEO and QZSS signals.

1.5.1 GPS

u-blox 7 receivers are designed to receive and track the L1C/A signals provided at 1575.42 MHz by the Global Positioning System (GPS). NEO-7P delivers the benefits of PPP carrier-phase tracking with GPS signals.

1.5.2 GLONASS

The Russian GLONASS satellite system is an alternative system to the US-based Global Positioning System (GPS). The u-blox 7 module is capable of receiving and processing GLONASS signals and provides the lowest power GLONASS functionality in the industry at low cost and with minimal integration effort. In order to take advantage of GPS and GLONASS, dedicated hardware preparation must be taken during the design-in phase, see the *MAX-7 / NEO-7 / LEA-7 Hardware Integration Manual*[1] for u-blox design recommendations.

Receiving and tracking GLONASS L1OF satellite signals with the same hardware results in an optimized hardware BOM and allows design of GLONASS ready receivers where required by regulations.

1.5.3 QZSS

The Quasi-Zenith Satellite System (QZSS) is a navigation satellite overlay system for the Pacific region covering Japan and Australia that transmits additional GPS L1C/A signals. u-blox 7 positioning modules are able to receive and track these signals simultaneously with GPS, resulting in better availability, especially under bad signal conditions e.g. in urban canyons.

1.6 Precise Point Positioning

Precise Point Positioning (PPP) encompasses a number of technologies that deliver enhanced precision compared with conventional single-point positioning receivers. The u-blox' NEO-7P module combines single-frequency carrier-phase tracking with code-phase measurements, and, if available, Space Based Augmentation Services (SBAS) to deliver sub-metre accuracy in a wide range of portable applications. Even without SBAS, u-blox' carrier-phase tracking technology significantly reduces mid-term measurement wander and delivers useful improvements in the accuracy of dynamic relative positioning over many minutes. NEO-7P also supports code-phase Differential GPS (DGPS) using industry-standard RTCM format messages as an alternative to SBAS and PPP. This enables world-wide precision applications on a common platform.

Space Based Augmentation Services (SBAS) provide supplementary correction data for satellite orbits and clocks, for atmospheric delays and satellite health monitoring. SBAS signals are broadcast from satellites in geo-stationary and quasi-synchronous orbits to users in many parts of the world including North America (WAAS), Japan (MSAS), Europe (EGNOS) and India (GAGAN). These data are generally more accurate and revised more often than the standard data transmitted by the satellites themselves and offer the potential for more accurate position calculations in real time.

For a stand-alone receiver, accuracy is then limited mainly by fast-changing and residual un-modelled delays in the ionosphere (upper atmosphere) and signal distortion from local reflections (multi-path). These limitations can be overcome partly in some applications by tens of minutes of static averaging at each location until an acceptably accurate location has been achieved. u-blox' industry-proven PPP algorithm uses carrier-phase tracking to reduce the impact of these residual errors dramatically without the need for static averaging, freeing the user from restrictions on measurement rate or movement.

Together, these features make the NEO-7P an ideal solution where speed of measurement and precision are required but deployment of a local reference station for Differential GPS is impossible, impractical or just inconvenient. Typical applications include many types of surveying, mapping, marine applications, agriculture and the control of cranes and other large machinery. The small form factor and low power consumption of NEO-7P also makes the benefits of PPP available outside the industrial market for sports and leisure applications bringing greater precision to measurements of track and range.

1.7 Raw data

Raw measurement output is supported for GPS signals at an update rate of up to 10 Hz. The UBX-RXM-RAW message includes carrier phase with half-cycle ambiguity resolved, code phase and Doppler measurements, that can be used in external applications that offer precision positioning, real-time kinematics (RTK) and attitude sensing. The UBX-RXM-SFRB message contains sub-frame data for GPS and SBAS satellites.

1.8 Differential-GPS

NEO-7P supports operation as a D-GPS rover as an alternative to PPP and SBAS corrections (applicable to GPS operation only). Industry-standard Radio Technical Commission for Maritime Services (RTCM) 2.3 D-GPS correction messages may be sent to any receiver port. The following message types are supported:

RTCM 2.3 Message Type	Description
1	Differential GPS Corrections
2	Delta Differential GPS Corrections
3	GPS Reference Station Parameters
9	GPS Partial Correction Set

Table 3: Differential GPS message types

If either message 1 or 9 is received, then the receiver will use the corrections delivered to provide a fix using the available SVs for which correction data are available. PPP and corrections from SBAS will be disabled

automatically until no further D-GPS data are received (time-out configurable). Corrections are applied to measurements as they are made with calculated positions reported immediately.

1.9 Augmented GPS

1.9.1 Assisted GPS (A-GPS)

A-GPS improves GPS performance by delivering aiding data to the GPS receiver via wireless networks or the Internet. Supplying information such as ephemeris, almanac, approximate last position, time and satellite status and an optional time synchronization signal significantly reduces Time to First Fix (TTFF) and improves acquisition sensitivity.

AssistNow Online and AssistNow Offline are u-blox' end-to-end A-GPS services for devices with or without network connectivity. AssistNow Online and AssistNow Offline can either be used alone or in combination. They are very easy to implement, require no additional hardware, and generate virtually no CPU load. All u-blox 7 modules support u-blox' AssistNow Online, AssistNow Offline and AssistNow Autonomous A-GPS services, and are OMA SUPL compliant.

AssistNow Online

With AssistNow Online, an internet-connected GPS device downloads assistance data from u-blox' AssistNow Online Service at system start-up. AssistNow Online is network operator independent and globally available. u-blox only sends ephemeris data for those satellites currently visible to the device requesting the data, thus minimizing the amount of data transferred.

AssistNow Offline

With AssistNow Offline, users download u-blox' Differential Almanac Correction Data from the Internet at their convenience. The correction data can either be stored in the GPS/GNSS receiver's Flash memory or in the memory of the application processor. Therefore, the service requires no connectivity at system start-up and enables a position fix within seconds, even when no network is available.

1.9.2 AssistNow Autonomous

AssistNow Autonomous provides functionality similar to Assisted-GPS without the need for a host or external network connection. It is an embedded feature available free-of-charge that accelerates GPS positioning by capitalizing on the periodic nature of GPS satellite orbits. GPS orbit predictions are directly calculated by the GPS receiver and no external aiding data or connectivity is required. AssistNow Autonomous can be used alone, or together with AssistNow Online or AssistNow Offline for increased positioning speed and accuracy.

For more details see the *u-blox 7 Receiver Description Including Protocol Specification* [2].

1.9.3 Satellite-Based Augmentation System (SBAS)

u-blox 7 positioning modules support SBAS. These systems supplement GPS data with additional regional or wide area GPS augmentation data. The system broadcasts augmentation data via satellite which can be used by GPS receivers to improve the resulting GPS precision. SBAS satellites can be used as additional satellites for ranging (navigation), further enhancing precision. The following SBAS are supported with u-blox 7: WAAS, EGNOS, MSAS and (subject to successful deployment) GAGAN.

For more details see the *u-blox 7 Receiver Description Including Protocol Specification* [2]

1.10 EXTINT: External interrupt

EXTINT is an external interrupt pin with fixed input voltage thresholds with respect to VCC. It can be used for control of the receiver or for aiding.

For more information about how to implement and configure these features, see the u-blox 7 Receiver Description including Protocol Specification [2] and the MAX-7 / NEO-7 / LEA-7 Hardware Integration Manual [1].

1.10.1 Pin Control

The pin control feature allows overriding the automatic active/inactive cycle of Power Save Mode. The state of the receiver can be controlled through the EXTINT pin.

The receiver can also be forced OFF using EXTINT when Power Save Mode is not active.

1.10.2 Aiding

The EXTINT pin can be used to supply time or frequency aiding data to the receiver.

For time aiding, hardware time synchronization can be achieved by connecting an accurate time pulse to the EXTINT pin.

Frequency aiding can be implemented by connecting a periodic rectangular signal with a frequency up to 500 kHz and arbitrary duty cycle (low/high phase duration must not be shorter than 50 ns) to the EXTINT pin. Provide the applied frequency value to the receiver using UBX messages.

1.11 TIMEPULSE

A configurable time pulse signal is available with all u-blox 7 modules.

The TIMEPULSE output generates pulse trains synchronized with GPS or UTC time grid with intervals configurable over a wide frequency range. Thus it may be used as a low frequency time synchronization pulse or as a high frequency reference signal.

By default, the time pulse signal is configured to 1 pulse per second. For more information, see the *u-blox 7 Receiver Description including Protocol Specification [2]*.

1.12 Protocols and interfaces

Protocol	Type
NMEA	Input/Output, ASCII, 0183, 2.3 (compatible to 3.0)
UBX	Input/Output, binary, u-blox proprietary
RTCM	Input, 2.3

Table 4: Protocols

All protocols are available on UART, USB, DDC (I²C compliant) and SPI. For specification of the various protocols, see the *u-blox 7 Receiver Description Including Protocol Specification [2]*.

1.13 Interfaces

A number of interfaces are provided either for data communication or memory access. The embedded firmware uses these interfaces according to their respective protocol specifications.

1.13.1 UART

NEO-7 modules include one UART interface, which can be used for communication to a host. It supports configurable baud rates. For supported baud rates, see the *u-blox 7 Receiver Description Including Protocol Specification [2]*.

1.13.2 USB

A USB version 2.0 FS compatible interface can be used for communication as an alternative to the UART. The pull-up resistor on pin USB_DP is integrated to signal a full-speed device to the host. The VDD_USB pin supplies the USB interface. u-blox provides a Microsoft® certified USB driver for Windows XP, Windows Vista and Windows 7 operating systems.

1.13.3 SPI

The SPI interface is designed to allow communication to a host CPU. The interface can be operated in slave mode only. The maximum transfer rate using SPI is 1 Mb/s and the maximum SPI clock frequency is 5.5 MHz. Note that SPI is not available in the default configuration, because its pins are shared with the UART and DDC interfaces. The SPI interface can be enabled by connecting D_SEL (Pin 2) to ground (see section 3.1).

1.13.4 Display Data Channel (DDC)

An I²C compliant DDC interface is available for communication with an external host CPU or u-blox wireless modules. The interface can be operated in slave mode only. The DDC protocol and electrical interface are fully compatible with Fast-Mode of the I²C industry standard. Since the maximum SCL clock frequency is 400 kHz, the maximum transfer rate is 400 kb/s.

1.14 Clock generation

1.14.1 Oscillators

The NEO-7P GPS module with PPP uses a quartz crystal oscillator.

1.14.2 Real-Time Clock (RTC)

The RTC is driven by a 32 kHz oscillator, which makes use of a separate RTC crystal. If the main supply voltage fails, and a battery is connected to V_BCKP, parts of the receiver switch off, but the RTC still runs and provides a timing reference for the receiver. This operating mode is called Hardware Backup Mode, which enables all relevant data to be saved in the backup RAM to later allow a hot or warm start.

1.15 Power management

u-blox 7 technology offers a power-optimized architecture with built-in autonomous power saving functions to minimize power consumption at any given time. An integrated high efficiency DC/DC converter allows low power consumption even for higher main supply voltages. The receiver can be operated in two operating modes: Continuous Mode or Power Save Mode.

1.15.1 DC/DC converter

NEO-7 modules integrate a DC/DC converter, allowing reduced power consumption especially when using a main supply voltage above 2.7 V.

For more information, see the MAX-7 / NEO-7 / LEA-7 Hardware Integration Manual [1]

1.15.2 Operating modes

u-blox 7 modules have two operating modes:

- Continuous Mode for best GPS/GNSS performance
- Power Save Mode to optimize power consumption

PPP relies on continuous carrier-phase tracking and is supported only in Continuous Mode.

1.15.2.1 Continuous Mode

Continuous Mode uses the acquisition engine at full performance, which results in the shortest possible TTFF and the highest sensitivity. It searches for all possible satellites until the Almanac is completely downloaded. The receiver then switches to the tracking engine to lower power consumption.

Thus, a lower tracking current consumption level will be achieved when:

- A valid GPS/GNSS position is obtained
- The entire Almanac has been downloaded
- The Ephemeris for each satellite in view is valid

1.15.2.2 Power Save Mode

For power sensitive applications, u-blox 7 receivers provide a Power Save Mode for reduced power consumption. Power Save Mode uses two dedicated operations called ON/OFF and Cyclic tracking, that reduce average current consumption in different ways to match the needs of the specific application. These operations can be set by using a specific UBX message.

For more information about power management strategies, see the *u-blox 7 Receiver Description Including Protocol Specification [2]*.

Power Save Mode is not available in GLONASS mode.

1.16 Antenna

NEO-7 modules are designed for use with passive and active¹⁴ antennas.

Parameter	Specification	
Antenna Type	Passive and active antenna	
Active Antenna Recommendations	Minimum gain	15 dB (to compensate for signal loss in RF cable)
	Maximum gain	50 dB
	Maximum noise figure	1.5 dB

Table 5: Antenna specifications

¹⁴ For more information on using active antennas with NEO-7 modules see the *MAX-7 / NEO-7 / LEA-7 Hardware Integration Manual [1]*.

2 Pin Definition

2.1 Pin assignment

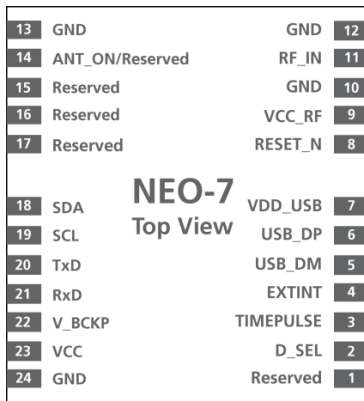

Figure 2: NEO-7 pin assignment

No	Name	I/O	Description
1	Reserved	I	Reserved
2	D_SEL	I	Interface select
3	TIMEPULSE	O	Time pulse (1PPS)
4	EXTINT	I	External Interrupt Pin
5	USB_DM	I/O	USB Data
6	USB_DP	I/O	USB Data
7	VDD_USB	I	USB Supply
8	RESET_N	I	RESET_N
9	VCC_RF	O	Output Voltage RF section
10	GND	I	Ground
11	RF_IN	I	GPS signal input
12	GND	I	Ground
13	GND	I	Ground
14	ANT_ON	O	Antenna control
15	Reserved	-	Reserved
16	Reserved	-	Reserved
17	Reserved	-	Reserved
18	SDA SPI CS_N	I/O	DDC Data if D_SEL =1 (or open) SPI Chip Select if D_SEL = 0
19	SCL SPI CLK	I/O	DDC Clock if D_SEL =1(or open) SPI Clock if D_SEL = 0
20	TxD SPI MISO	O	Serial Port if D_SEL =1(or open) SPI MISO if D_SEL = 0
21	RxD SPI MOSI	I	Serial Port if D_SEL =1(or open) SPI MOSI if D_SEL = 0
22	V_BCKP	I	Backup voltage supply
23	VCC	I	Supply voltage
24	GND	I	Ground

Table 6: NEO-7 pin descriptions

Pins designated Reserved should not be used. For more information about Pinouts see the *MAX-7/NEO-7/LEA-7 Hardware Integration Manual [1]*.

3 Configuration management

Configuration settings can be modified with UBX configuration messages. The modified settings remain effective until power-down or reset. If these settings have been stored in battery-backup RAM, then the modified configuration will be retained, as long as the backup battery supply is not interrupted.

Optionally, configuration settings modified with UBX configuration messages can be saved permanently to SPI flash memory. In this case, the modified settings remain effective even after power-down and do not require backup battery supply.

3.1 Interface Selection (D_SEL)

At startup, the Pin 2 (D_SEL) determines which data interfaces are used for communication. If D_SEL is set high or left open, UART and DDC become available. If D_SEL is set low, i.e. connected to ground, the NEO Module can communicate to a host via SPI.

Pin #	D_SEL="1" (left open)	D_SEL="0" (pulled to GND)
18	DDC SDA	SPI CS_N
19	DDC SCL	SPI CLK
20	UART TX	SPI MISO
21	UART RX	SPI MOSI

Table 7: Interface selection pins

4 Electrical specification

The limiting values given are in accordance with the Absolute Maximum Rating System (IEC 134). Stress above one or more of the limiting values may cause permanent damage to the device. These are stress ratings only, and operation of the device at these or at any other conditions above those given in the Characteristics sections of the specification is not implied. Exposure to these limits for extended periods may affect device reliability. Where application information is given, it is advisory only and does not form part of the specification. For more information see the *MAX-7 / NEO-7 / LEA-7 Hardware Integration Manual [1]*.

4.1 Absolute maximum ratings

Parameter	Symbol	Condition	Min	Max	Units
Power supply voltage	VCC		-0.5	3.6	V
Backup battery voltage	V_BCKP		-0.5	3.6	V
USB supply voltage	VDD_USB		-0.5	3.6	V
Input pin voltage	V _{in}		-0.5	3.6	V
	V _{in_usb}		-0.5	VDD_USB	V
DC current through any digital I/O pin (except supplies)	I _{pin}			10	mA
VCC_RF output current	ICC_RF			100	mA
Input power at RF_IN	Pr _{fin}	source impedance 50Ω continuous wave		13	dBm
Storage temperature	T _{stg}		-140	85	°C

Table 8: Absolute maximum ratings

Stressing the device beyond the “Absolute Maximum Ratings” may cause permanent damage. These are stress ratings only. The product is not protected against overvoltage or reversed voltages. If necessary, voltage spikes exceeding the power supply voltage specification, given in table above, must be limited to values within the specified boundaries by using appropriate protection diodes.

4.2 Operating conditions

All specifications are at an ambient temperature of 25°C. Extreme operating temperatures can significantly impact specification values. Applications operating near the temperature limits should be tested to ensure the specification.

Parameter	Symbol	Min	Typical	Max	Units	Condition	
Power supply voltage	VCC	2.7	3.0	3.6	V		
Supply voltage USB	VDDUSB	3.0	3.3	3.6	V		
Backup battery voltage	V_BCKP	1.4		3.6	V		
Input pin voltage range	V _{in}	0		VCC	V		
Digital IO Pin Low level input voltage	V _{il}	0		0.2*VCC	V		
Digital IO Pin High level input voltage	V _{ih}	0.7*VCC		VCC	V		
Digital IO Pin Low level output voltage	V _{ol}			0.4	V	I _{ol} =4mA	
Digital IO Pin High level output voltage	V _{oh}	VCC -0.4			V	I _{oh} =4mA	
Digital Input Pin pull-up: RESET_N, SCL, SDA, EXTINT ¹⁵	R _{pu}		11		kΩ		
Digital Input Pin pull-up: D_SEL, RxD	R _{pu}		115		kΩ		
Digital Output Pin pull-up: TIMEPULSE	R _{pu}		11		kΩ	backup mode only ¹⁶	
Digital Output Pin pull-up: TxD	R _{pu}		115		kΩ	backup mode only ¹⁶	
Digital Output Pin pull-up: ANT_ON	R _{pu}		115		kΩ	during reset only ¹⁶	
USB_DM, USB_DP	V _{inU}	Compatible with USB with 22 Ω series resistance					
VCC_RF voltage	VCC_RF		VCC-0.1		V		
VCC_RF output current	ICC_RF			50	mA		
Receiver Chain Noise Figure	NF _{tot}		5		dB		
Operating temperature	T _{opr}	-40		85	°C		

Table 9: Operating conditions

Operation beyond the specified operating conditions can affect device reliability.

¹⁵ EXTINT pull-up is disabled when pin driven LOW

¹⁶ Output pins are positively driven in all other modes

4.3 Indicative current requirements

Table 9 lists examples of the total system supply current for a possible application.

Values in Table 9 are provided for customer information only as an example of typical power requirements. Values are characterized on samples, actual power requirements can vary depending on FW version used, external circuitry, number of SVs tracked, signal strength, type of start as well as time, duration and conditions of test.

Parameter	Symbol	Min	Typical	Max	Units	Condition
Max. supply current ¹⁷	I _{ccp}			63	mA	3V
Average supply current (active) ^{18 19}	I _{cc} Acquisition ²⁰		28		mA	3V
	I _{cc} Tracking (continuous mode/PPP)		22		mA	3V
	ICC Tracking (Power Save mode / 1Hz)		9		mA	3V
Backup battery current	I _{BCKP}		15		μA	V _{BCKP} = 1.8 V, V _{CC} = 0V

Table 10: Current requirements

For more information about power requirements, see the *MAX-7 / NEO-7 / LEA-7 Hardware Integration Manual [1]*.

¹⁷ Use this figure to dimension maximum current capability of power supply. Measurement of this parameter with 1Hz bandwidth.

¹⁸ Use these figures to determine required battery capacity.

¹⁹ Simulated constellation of 8 satellites in view. All signals are at -130dBm.

²⁰ Average current from start-up until the first fix.

4.4 SPI timing diagrams

In order to avoid incorrect operation of the SPI, the user needs to comply with certain timing conditions. The following signals need to be considered for timing constraints:

Symbol	Description
SPI CS_N (SS_N)	Slave select signal
SPI CLK (SCK)	Slave clock signal

Table 11: Symbol description

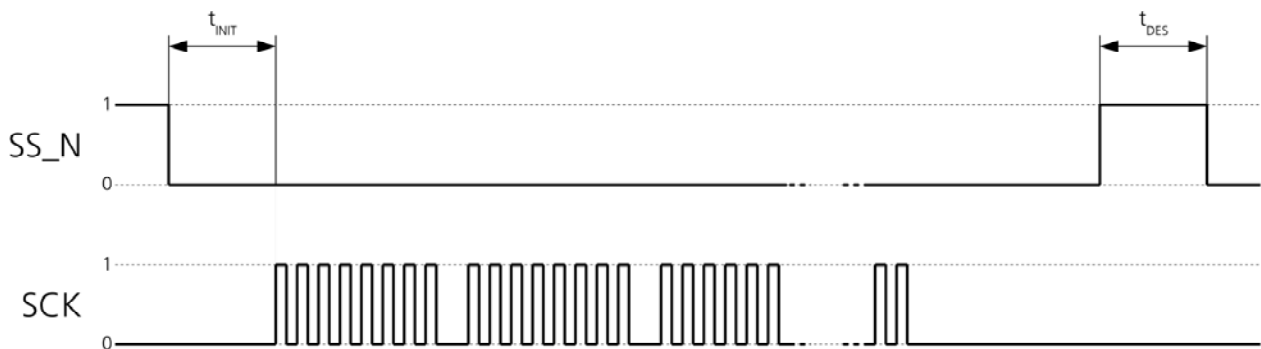

Figure 3: SPI timing diagram

4.4.1 Timing recommendations

The recommendations below are based on a firmware running from Flash memory.

Parameter	Description	Recommendation
t_{INIT}	Initialization Time	500 μ s
t_{DES}	Deselect Time	1 ms.
Bit rate		1 Mb/s

Table 12: SPI timing recommendations



The values in the above table result from the requirement of an error-free transmission. By allowing just a few errors and disabling the glitch filter, the bit rate can be increased considerably.

4.5 DDC timing diagrams

The DDC interface is I²C Fast Mode compliant. For timing parameters consult the I²C standard.



The maximum bit rate is 400 kb/s. The interface stretches the clock when slowed down when serving interrupts, so real bit rates may be slightly lower.

5 Mechanical specifications

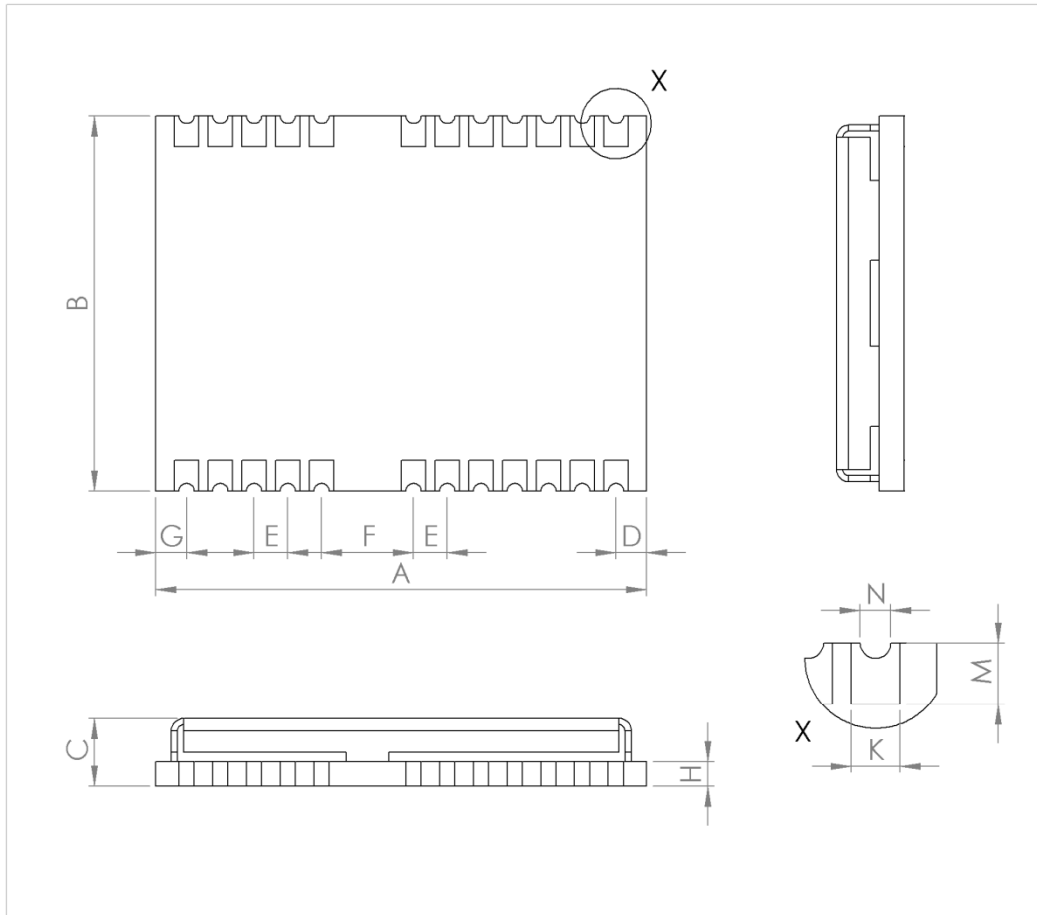

Symbol	Min. (mm)	Typ. (mm)	Max. (mm)
A	15.9	16.0	16.6
B	12.1	12.2	12.3
C	2.2	2.4	2.6
D	0.9	1.0	1.3
E	1.0	1.1	1.2
F	2.9	3.0	3.1
G	0.9	1.0	1.3
H		0.82	
K	0.7	0.8	0.9
M	0.8	0.9	1.0
N	0.4	0.5	0.6
Weight		1.6g	

Figure 4: Dimensions



For information regarding the Paste Mask and Footprint see the MAX-7 / NEO-7 / LEA-7 Hardware Integration Manual [1].

6 Reliability tests and approvals

6.1 Reliability tests



All NEO-7 modules are based on AEC-Q100 qualified GPS chips.

Tests for product family qualifications are according to ISO 16750 "Road vehicles - Environmental conditions and testing for electrical and electronic equipment", and appropriate standards.

6.2 Approvals



Products marked with this lead-free symbol on the product label comply with the "Directive 2002/95/EC of the European Parliament and the Council on the Restriction of Use of certain Hazardous Substances in Electrical and Electronic Equipment" (RoHS).

All u-blox 7 GNSS modules are RoHS compliant.

7 Product handling & soldering

7.1 Packaging

NEO-7 modules are delivered as hermetically sealed, reeled tapes in order to enable efficient production, production lot set-up and tear-down. For more information see the *u-blox Package Information Guide* [2].

7.1.1 Reels

NEO-7 GPS modules are deliverable in quantities of 250pcs on a reel. NEO-7 modules are shipped on Reel Type B, as specified in the *u-blox Package Information Guide* [2].

7.1.2 Tapes

The dimensions and orientations of the tapes for NEO-7 modules are specified in Figure 5.

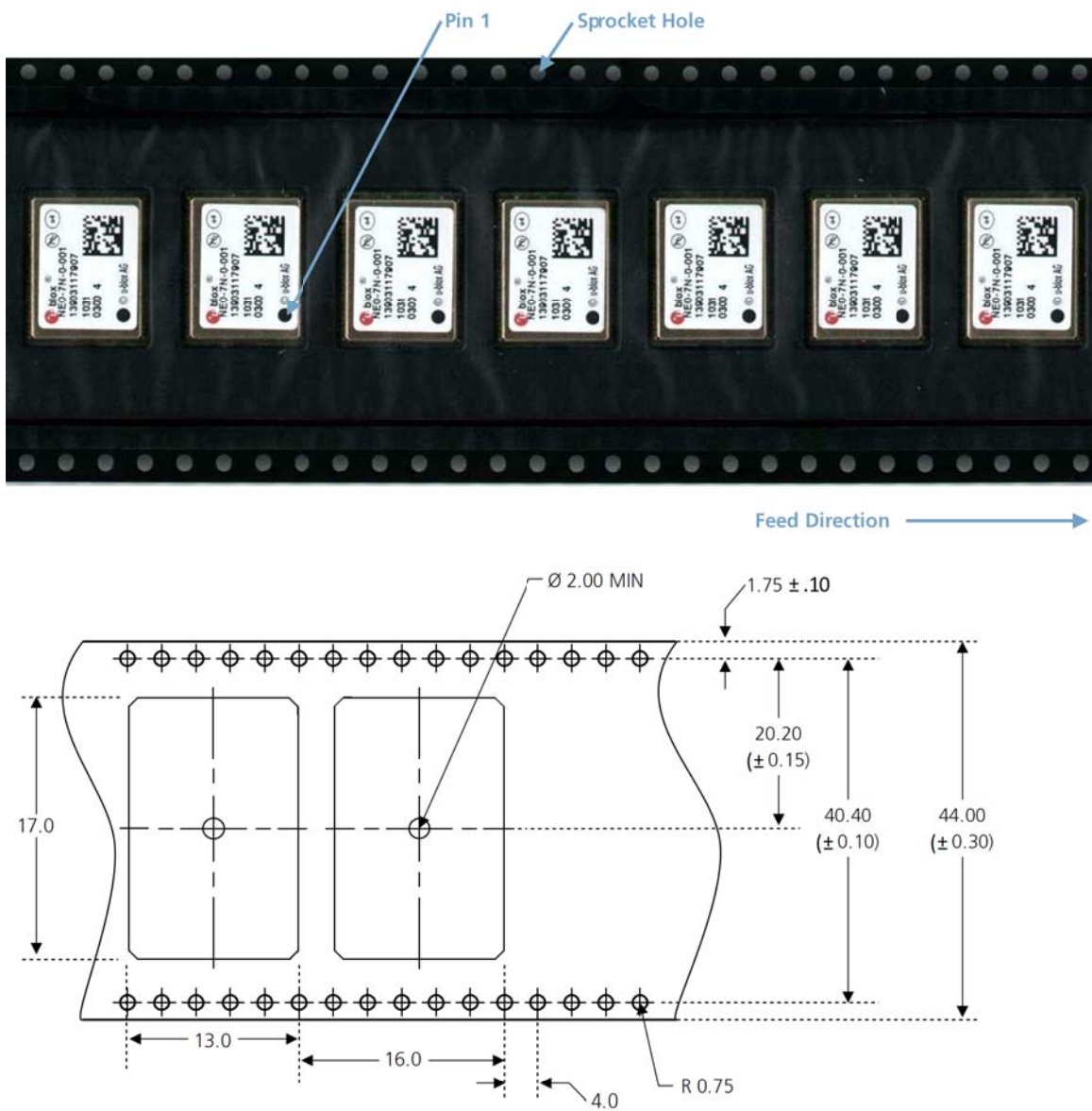

Figure 5: Dimensions and orientation for NEO-7 modules on tape

7.2 Shipment, storage and handling

For important information regarding shipment, storage and handling see the *u-blox Package Information Guide* [2].

7.2.1 Moisture Sensitivity Levels

The Moisture Sensitivity Level (MSL) relates to the packaging and handling precautions required. NEO-7 modules are rated at MSL level 4.



For MSL standard see IPC/JEDEC J-STD-020, which can be downloaded from <http://www.jedec.org/>

For more information regarding MSL see the *u-blox Package Information Guide* [2].

7.2.2 Reflow soldering

Reflow profiles are to be selected according u-blox recommendations (see *MAX-7 / NEO-7 / LEA-7 Hardware Integration Manual*[1]).

7.2.3 ESD handling precautions



NEO-7 modules are Electrostatic Sensitive Devices (ESD). Observe precautions for handling! Failure to observe these precautions can result in severe damage to the GPS receiver!

GPS receivers are Electrostatic Sensitive Devices (ESD) and require special precautions when handling. Particular care must be exercised when handling patch antennas, due to the risk of electrostatic charges. In addition to standard ESD safety practices, the following measures should be taken into account whenever handling the receiver:

- Unless there is a galvanic coupling between the local GND (i.e. the work table) and the PCB GND, then the first point of contact when handling the PCB must always be between the local GND and PCB GND.
- Before mounting an antenna patch, connect ground of the device
- When handling the RF pin, do not come into contact with any charged capacitors and be careful when contacting materials that can develop charges (e.g. patch antenna ~10pF, coax cable ~50-80pF/m, soldering iron, ...)
- To prevent electrostatic discharge through the RF input, do not touch any exposed antenna area. If there is any risk that such exposed antenna area is touched in non ESD protected work area, implement proper ESD protection measures in the design.
- When soldering RF connectors and patch antennas to the receiver's RF pin, make sure to use an ESD safe soldering iron (tip).



8 Default messages

Interface	Settings
UART Output	9600 Baud, 8 bits, no parity bit, 1 stop bit Configured to transmit both NMEA and UBX protocols, but only following NMEA and no UBX messages have been activated at start-up: GGA, GLL, GSA, GSV, RMC, TXT
USB Output	Configured to transmit both NMEA and UBX protocols, but only following NMEA and no UBX messages have been activated at start-up: GGA, GLL, GSA, GSV, RMC, TXT USB Power Mode: Bus Powered
UART Input	9600 Baud, 8 bits, no parity bit, 1 stop bit, Autobauding disabled Automatically accepts following protocols without need of explicit configuration: UBX, NMEA The GPS receiver supports interleaved UBX and NMEA messages.
USB Input	Automatically accepts following protocols without need of explicit configuration: UBX, NMEA The GPS receiver supports interleaved UBX and NMEA messages. USB Power Mode: Bus Powered
TIMEPULSE (1Hz Nav)	1 pulse per second, synchronized at rising edge, pulse length 100ms

Table 13: Default messages



Refer to the *u-blox 7 Receiver Description Including Protocol Specification* [2] for information about further settings.

9 Labeling and ordering information

9.1 Product labeling

The labeling of u-blox 7 GPS modules includes important product information. The location of the product type number is shown in Figure 6.

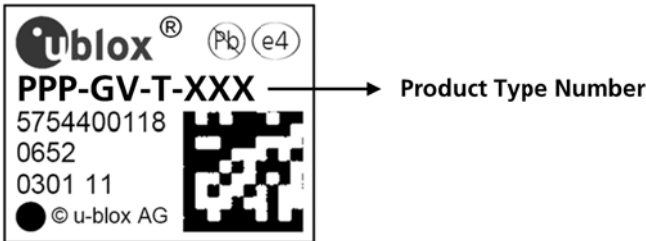

Figure 6: Location of product type number on u-blox 7 module label

9.2 Explanation of codes

3 different product code formats are used. The **Product Name** is used in documentation such as this data sheet and identifies all u-blox 7 products, independent of packaging and quality grade. The **Ordering Code** includes options and quality, while the **Type Number** includes the hardware and firmware versions. Table 14 below details these 3 different formats:

Format	Structure
Product Name	PPP-GV
Ordering Code	PPP-GV-T
Type Number	PPP-GV-T-XXX

Table 14: Product Code Formats

The parts of the product code are explained in Table 15.

Code	Meaning	Example
PPP	Product Family	NEO
G	Product Generation	7 = u-blox7
V	Variant	T = Timing, P = PPP, R = DR, etc.
T	Option / Quality Grade	Describes standardized functional element or quality grade such as Flash size, automotive grade etc.
XXX	Product Detail	Describes product details or options such as hard- and software revision, cable length, etc.

Table 15: part identification code

9.3 Ordering codes

Ordering No.	Product
NEO-7P-0	u-blox 7 LCC Module, GPS/GNSS Precise Point Positioning, Raw Data 12x16 mm, 250 pcs/reel, 3 V

Table 16: Product ordering codes for standard grade modules



Product changes affecting form, fit or function are documented by u-blox. For a list of Product Change Notifications (PCNs) see our website.

Related documents

- [1] MAX-7 / NEO-7 / LEA-7 Hardware Integration Manual, Docu. No. GPS.G7-HW-11006
- [2] u-blox 7 Receiver Description including Protocol Specification, Docu. No GPS.G7-SW-12001
- [3] u-blox Package Information Guide, Docu. No. GPS-X-11004

For complete contact information visit us at www.u-blox.com

Revision history

Revision	Date	Name	Status / Comments
-	June 7, 2013	dhur	Initial release

Contact

u-blox Offices

North, Central and South America

u-blox America, Inc.

Phone: +1 703 483 3180
E-mail: info_us@u-blox.com

Regional Office West Coast:

Phone: +1 408 573 3640
E-mail: info_us@u-blox.com

Technical Support:

Phone: +1 703 483 3185
E-mail: support_us@u-blox.com

Headquarters Europe, Middle East, Africa

u-blox AG

Phone: +41 44 722 74 44
E-mail: info@u-blox.com
Support: support@u-blox.com

Asia, Australia, Pacific

u-blox Singapore Pte. Ltd.

Phone: +65 6734 3811
E-mail: info_ap@u-blox.com
Support: support_ap@u-blox.com

Regional Office China (Beijing):

Phone: +86 10 68 133 545
E-mail: info_cn@u-blox.com
Support: support_cn@u-blox.com

Regional Office China (Shenzhen):

Phone: +86 755 8627 1083
E-mail: info_cn@u-blox.com
Support: support_cn@u-blox.com

Regional Office India:

Phone: +91 959 1302 450
E-mail: info_in@u-blox.com
Support: support_in@u-blox.com

Regional Office Japan:

Phone: +81 3 5775 3850
E-mail: info_jp@u-blox.com
Support: support_jp@u-blox.com

Regional Office Korea:

Phone: +82 2 542 0861
E-mail: info_kr@u-blox.com
Support: support_kr@u-blox.com

Regional Office Taiwan:

Phone: +886 2 2657 1090
E-mail: info_tw@u-blox.com
Support: support_tw@u-blox.com