

U\$1G\$2

PA3/USART2\_RX  
 VSS2  
 VDD2  
 PA4/SPI1\_NSS/SPI3\_NSS/USART2\_CK  
 PA5/SPI1\_SCK  
 PA6/SPI1\_MISO  
 PA7/SPI1\_MOSI  
 PC4  
 PC5  
 PB0  
 PB1  
 PB2/BOOT1  
 PE7  
 PE8  
 PE9  
 PE10  
 PE11  
 PE12  
 PE13  
 PE14  
 PE15  
 PB10/I2C2\_SCL/SPI2\_SCK/USART3\_TX  
 PB11/I2C2\_SDA/USART3\_RX  
 VCAP\_1  
 VDD3

STM32F407VX\_LQFP100

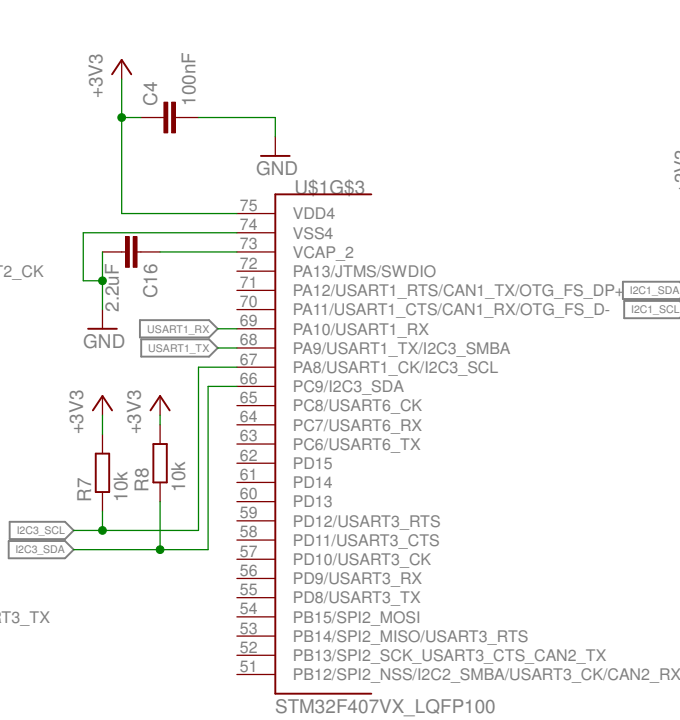

STM32F407VX\_LQFP100

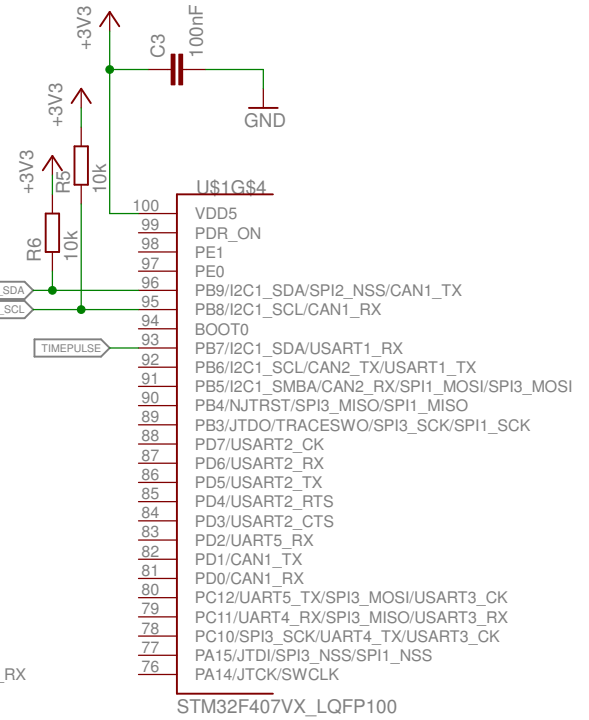

STM32F407VX\_LQFP100

NEO-7P

